

# BEFESTIGUNGSWINKEL

## MOUNTING BRACKETS / EQUERRES

DIN 41307 – Form W – Größe 3 a bis 5 a

### Form W – Größe 3 a bis 4 a

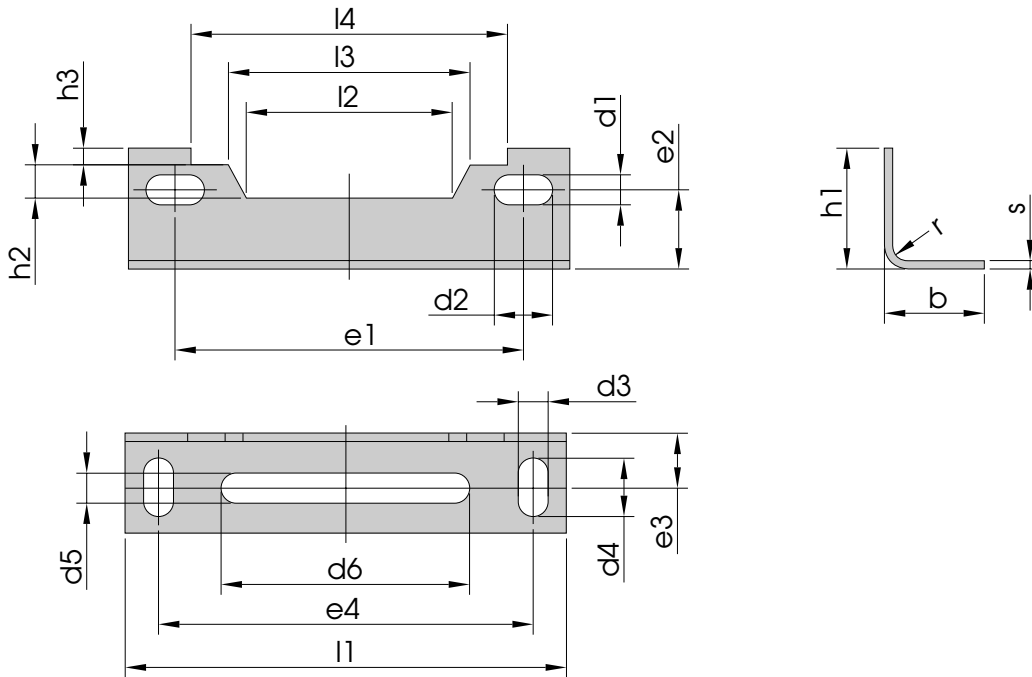

### Form W – Größe 5 a

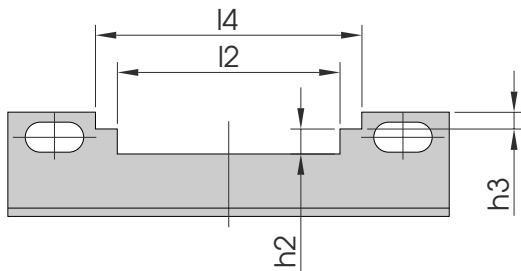

Übrige Maße wie Größe 3 a und 4 a

**Werkstoff:** Stahlblech verzinkt / Steel verz. / acier

Artikel-Nr.	Form und Größe	für Typ	magn. Achse s. w.		b	d <sub>1</sub>	d <sub>2</sub>	d <sub>3</sub>	d <sub>4</sub>	d <sub>5</sub>	d <sub>6</sub>	e <sub>1</sub>	e <sub>2</sub>	e <sub>3</sub>	e <sub>4</sub>	h <sub>1</sub>	h <sub>2</sub>	h <sub>3</sub>	l <sub>1</sub>	l <sub>2</sub>	l <sub>3</sub>	l <sub>4</sub>	r	s
<b>1030</b>	<b>W 3 a</b>	EI 48	x	–	13	3,6	7,0	3,6	7	3,6	30	36	7,5	7,5	38	14,5	5	3	46	25	29	32	1,6	1
		EI 54	–	x	13	3,6	7,0	3,6	7	3,6	30	36	7,5	7,5	38	14,5	5	3	46	25	29	32	1,6	1
<b>1040</b>	<b>W 4 a</b>	M 55	x	x	13	3,6	7,0	3,6	7	3,6	35	43,5	9,5	7,5	44	15	4	2	55	32	35	40	1,6	1
		EI 54	x	–	13	3,6	7,0	3,6	7	3,6	35	43,5	9,5	7,5	44	15	4	2	55	32	35	40	1,6	1
		EI 60	–	x	13	3,6	7,0	3,6	7	3,6	35	43,5	9,5	7,5	44	15	4	2	55	32	35	40	1,6	1
<b>1050</b>	<b>W 5 a</b>	EI 60	–	x	13	3,6	7,0	3,6	7	3,6	35	50	9,5	7,5	44	16	4	3	60	38	–	45	1,6	1
		EI 66	–	x	13	3,6	7,0	3,6	7	3,6	35	50	9,5	7,5	44	16	4	3	60	38	–	45	1,6	1



# BEFESTIGUNGSWINKEL

## MOUNTING BRACKETS / EQUERRES

DIN 41307 – Form W – Größe 14 a bis 22 a

### Form W – Größe 16 a

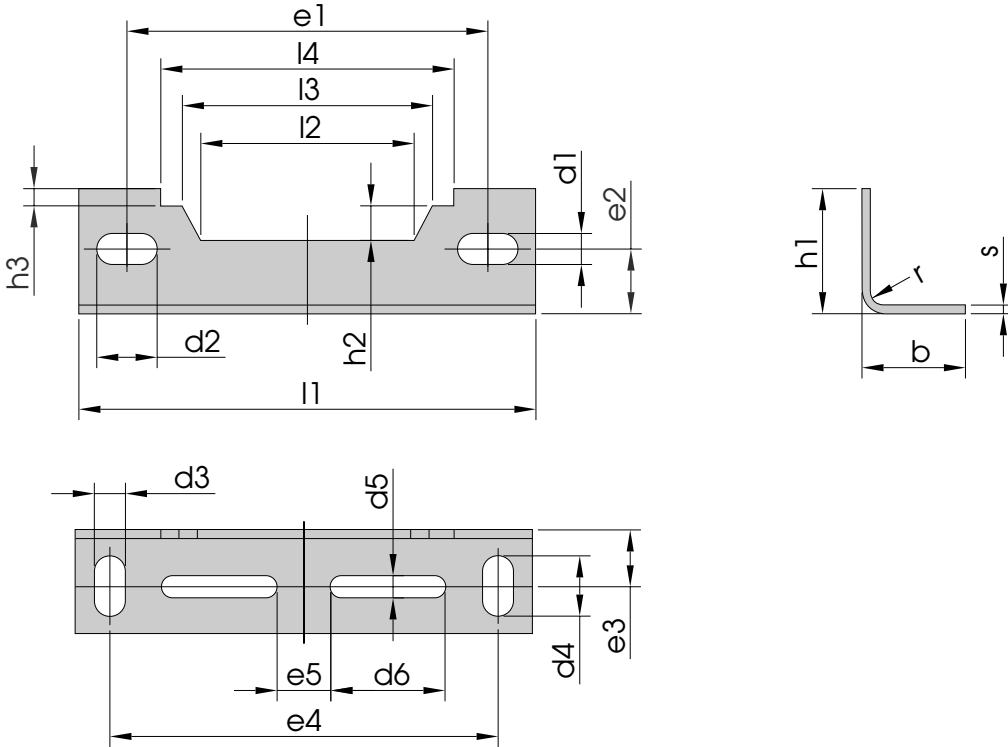

### Form W – Größe 14 a und 15 a, 17 a bis 22 a

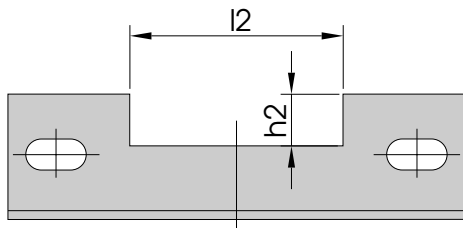

Übrige Maße wie Größe 16 a

**Werkstoff:** Stahlblech verzinkt / Steel verz. / acier

Artikel-Nr.	Form und Größe	für Typ	magn. Achse s.	w.	b	d <sub>1</sub>	d <sub>2</sub>	d <sub>3</sub>	d <sub>4</sub>	d <sub>5</sub>	d <sub>6</sub>	e <sub>1</sub>	e <sub>2</sub>	e <sub>3</sub>	e <sub>4</sub>	e <sub>5</sub>	h <sub>1</sub>	h <sub>2</sub>	h <sub>3</sub>	l <sub>1</sub>	l <sub>2</sub>	l <sub>3</sub>	l <sub>4</sub>	r	s
1140	W 14 a	EI 92	x	–	15	4,8	4,8	4,8	9	3,6	30	82	11	8,5	76	5	20	7,5	–	92	70	–	–	1,6	1,5
1150	W 15 a	EI 96	x	–	20	5,8	5,8	5,8	11	3,6	35	80	14	12	84	3	26	10,5	–	96	66	–	–	2,5	2,0
1160	W 16 a	M 102 EI 106	x x	x –	20	5,8	11	5,8	11	3,6	35	88,5	14	12	84	3	25	4,5	5	104	68	74	77	2,5	2,0
1170	W 17 a	EI 120	x	–	22	7	7	5,8	11	3,6	35	100	15	14	90	3	27	9,5	–	120	80	–	–	2,5	2,0
1180	W 18 a	EI 130	x	–	25	7	8,5	5,8	11	3,6	35	115	16	17	104	5	30	10,5	–	130	94	–	–	2,5	2,0
1190	W 19 a	EI 150 EI 150 N	x x	– –	27	8	15	7	13	5,2	44	128	19	17	122	5	33,5	12	–	150	109	–	–	2,5	2,5
1200	W 20 a	EI 170	x	–	27	8,5	12,5	7	13	5,2	44	147	17	17	135	5	32	13	–	170	122	–	–	2,5	2,5
1210	W 21 a	EI 195	x	–	35	11	11	10	18	5,2	54	170	21	20	150	5	40	13	–	195	140	–	–	4,0	3,0
1220	W 22 a	EI 231	x	–	40	13	13	12	18	–	–	201	25	25	180	–	46,5	14,5	–	231	166	–	–	6,0	4,0